



MOHEDA CRANE WITH LONG REACH.

K31T is a strong and robust crane, built for tough challenges in the forest.

Moheda K31T is intended for Moheda forest trailers M91 and M101. K31T is a flexible and strong crane with a good reach.

The K31T is a flexible and strong crane with good reach. It is equipped with a telescopic arm and has a reach of 6.5 metres. The K31T lifts 260 kg at full reach and has a slewing force of 8.5 kNm.

The linkage system gives a better movement pattern and a

smoother crane run. The overhead cylinders are well protected and provide good lifting torque within the working area.

As standard, the crane is equipped with CR300 rotator, FB160 grapple and multi-lever valve.

There are numerous valve packages and accessories to choose from.

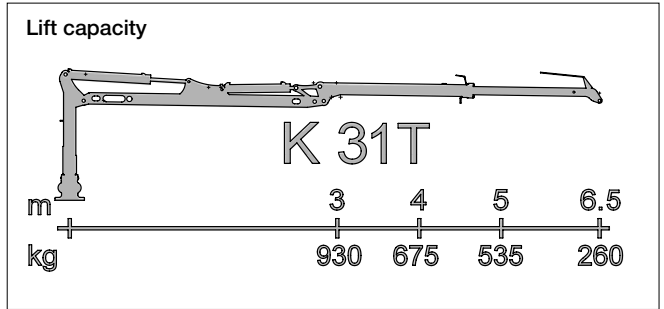
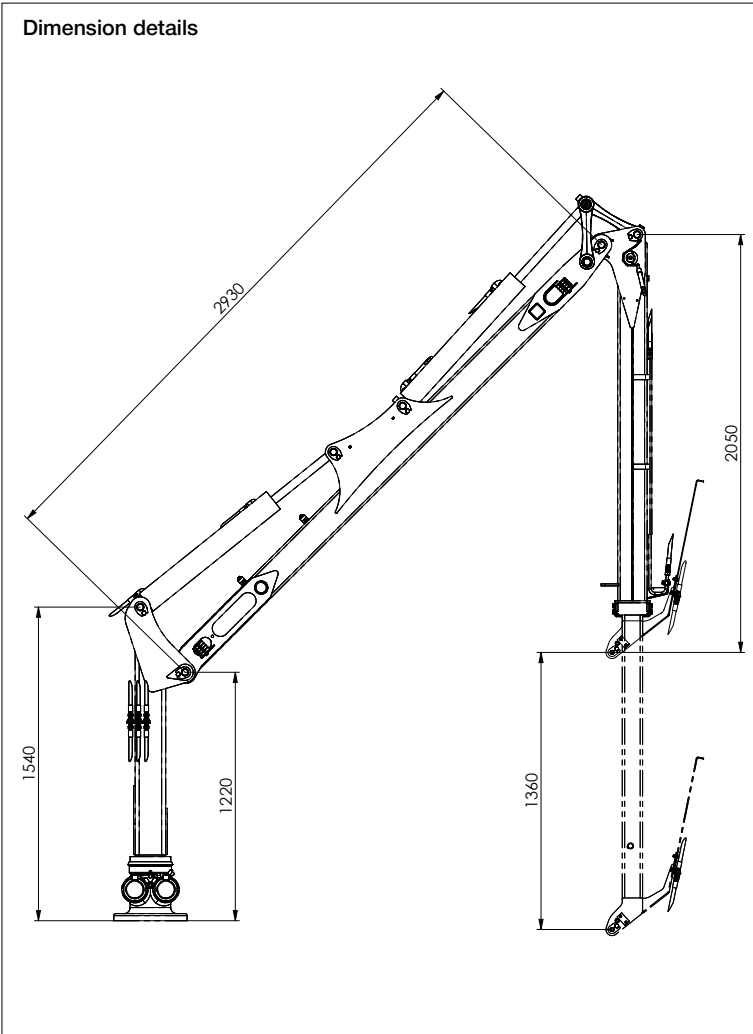
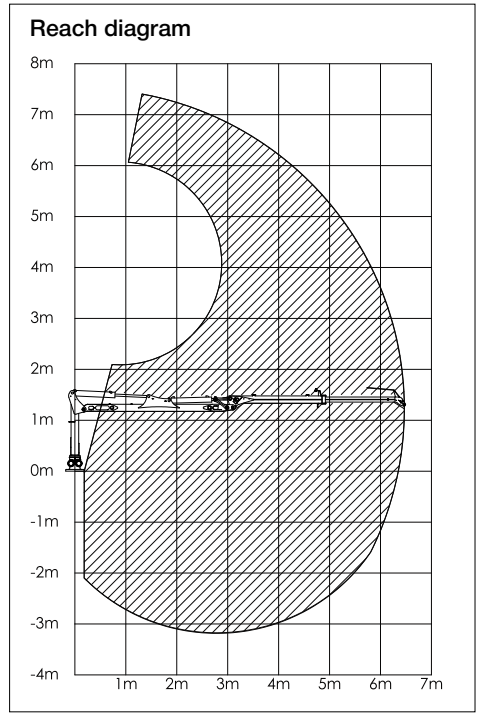

Technical data

K31T	
Reach (m)	6,5
Lift torque (kNm)	23
Lift capacity, max reach (kg)	260
Lift capacity, 4m (kg)	675
Slew torque (kNm)	8,5
Slew angle	360 °
Rec. oil flow (l/min) 4	25-35
Working pressure (bar)	180
Weight without grapple and rotator (kg)	620

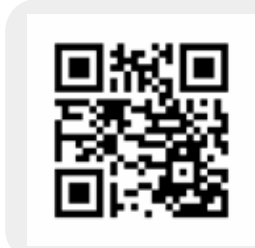

Scan the QR code for more information about the K31T crane



FTG Cranes AB
 Industrigatan 1,
 SE-668 40 Bäckefors, Sweden
 Tel: +46 (0)521-26 26 30
 info@ftgforest.com
www.ftgmoheda.com

Moheda cranes are designed and manufactured in Dalsland, Sweden. We have a long experience in designing and manufacturing powerful and high performance cranes. The Moheda brand, which dates back to 1835, has been associated with Swedish-made quality forest trailers since the 1960s. This is something that we cherish and develop every day!